



## **Portable Air Conditioner**

Compact Series: PC-BM1D

# Design

**Cooling** Kitchen Air Conditioning  
**Heating** Blanket Warming  
**Dehumidifying** Clothes/Blanket Drying  
**Ventilating** Basement/Closet Refreshing

Model	PC-BM1D
Capacity (BTU)	7,000~9,000
Dehumidification	20~50 L/ Day
Air Volume	360 m <sup>3</sup> /Hr
Noise	< 65 dB
40'HQ Container Loading	650~700pcs



# Design

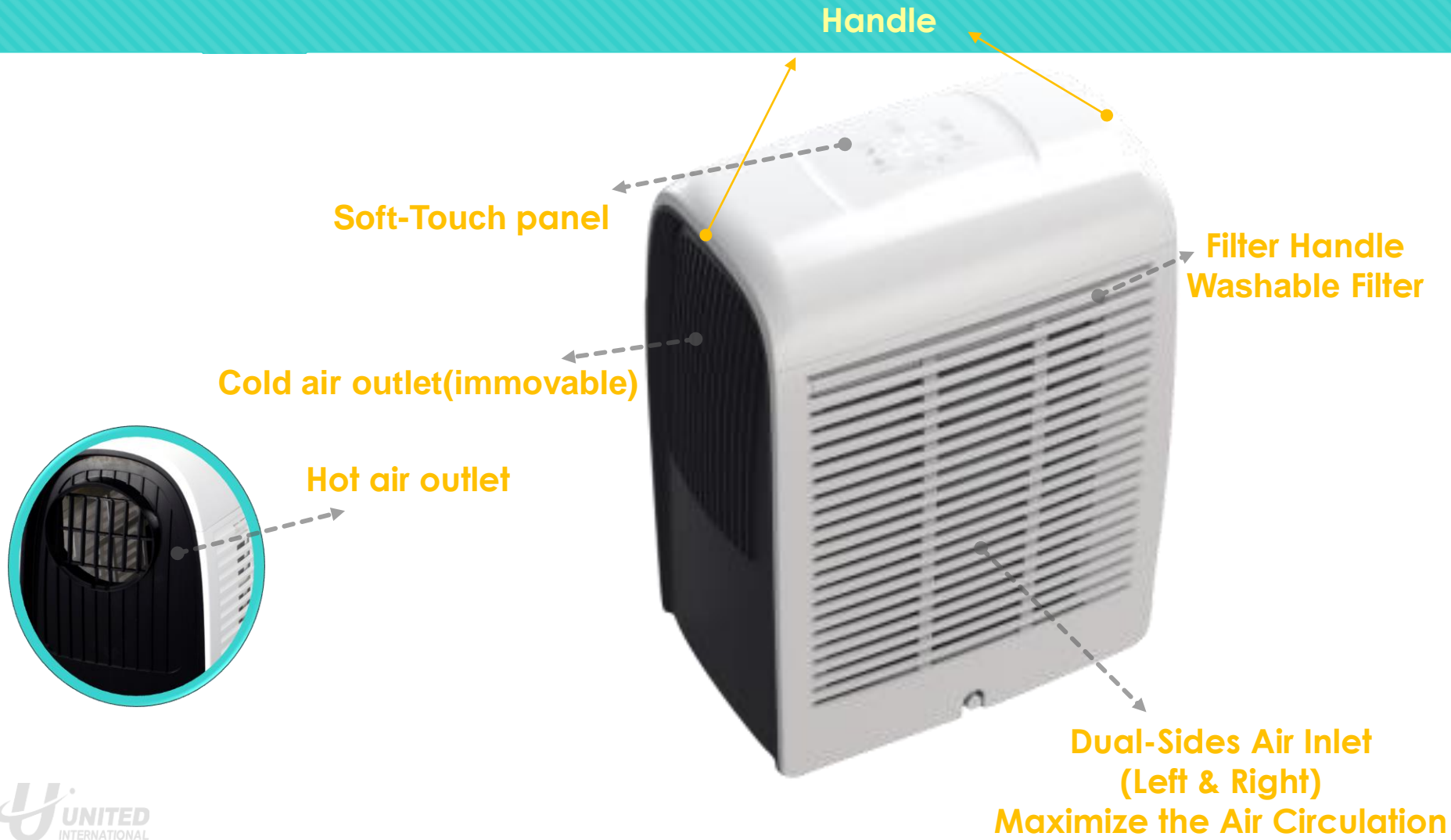

# More Selection



PC-BMA



PC-BMD



PC-BM1D



PC-KMA



PC-BMF



PC-BMG

# Functions

- ① Strong Cooling Capacity
- ② 50L Continuous Dehumidifying
- ③ Dry Clothes & Warm Shoes
- ④ 360m<sup>3</sup>/Hr Quick ventilation
- ⑤ 3-Speeds Control
- ⑥ Timer Setting 0-24Hr
- ⑦ SLEEP Program



# Functions

- **Inimitable Build-in Hose Design:**  
Combined with high density structural technology, elegant appearance, save space, easy storage, high loading.
- **“Hot/ Cold Air Outlet Exchange” design:**  
Convenient to use during season changing! The unit can be placed outdoors operating with the window kits, saving space and improving cooling / warming efficiency.
- **Use Branded Motor & Compressor:**  
Quick start with powerful performance. Improve the Self-Defrost function efficiency to keep the unit stable even at low temperature.
- **Higher Efficiency Self-Evaporating Technology:**  
Comparing to others, we lead part of condensation cooling down the internal working parts, which not only improves the unit’s working efficiency but also strengthen the condensing water self-evaporation more efficiently. This ensures the unit is free from draining in either cooling or heating mode for long period operating.
- **Multiple Program Settings:**  
Adjust the temperature or humidity anytime to adapt to the fickle weather. Equipped with 24-Hour timer to automatic turn on or off and operate in desired mode.

Features	
Control	Electric
Multifunction	4 Mode
Speed	3+1
Timer	✓
Dehumidifying	✓
Clothes Drying	✓
Built-in Exhaust Hose	✓
Sleeping Mode	✓
Temperature and Humidity Display	✓
Remote Control	✓
Automatic defrost	✓
Self-Diagnosis	✓

# Parameter

Model (CE/GS Certified)	PC20-BM1D	PC26-BM1D
Cooling capacity(W)	2000	2600
Cooling capacity(BTU)	7000	9000
Moisture removed(L/Day)	30	50
Air volume (m <sup>3</sup> /h)	360	360
Noise(dB)	63	65
Refrigerant	R410a	R410a
Net weight (kg)	22.5	23.5
Gross weight (kg)	24.5	25.5
Unit dimensions (mm)	W290*D433*H627	W290*D433*H627
Packing dimensions (mm)	W372*D537*H694	W372*D537*H694
Container Loading (20' / 40'GP/ 40'HQ)	216/ 459/ 610	216/ 459/ 610

# Features

## Built-In Duct Design

- Easy to pack the unit
- Save the storing space
- Good looking

Unique storage space for hiding exhaust hose inside the unit, good for delivering and storage.

- **For Wholesaler/ Retailer:**

Convenient to pack products, lower the cost for shipping/ transporting/ warehousing, and decrease the possibility of hose maintenance.

- **For Consumer/ User:**

Convenient to store in house, easily protect the exhaust hose from being crushed or lost, and save the space for using or storage.

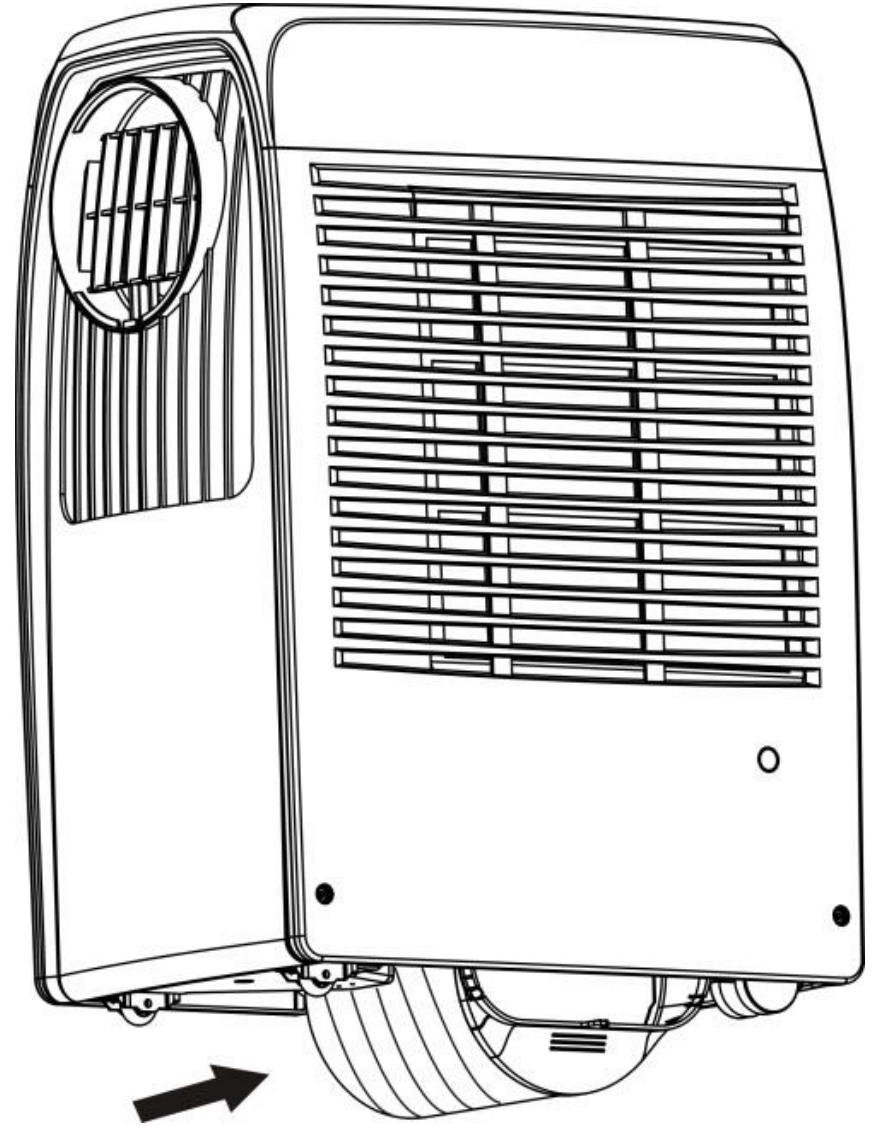



# Benefits

## □ Product Package:

We can directly store it in the unit, and directly package the whole unit.

However, the exhaust hose of other products n market can only be placed in the top or bottom of the package foam. Thus, the overall packaging height increase by 15~20 cm(depends on the diameter of the duct) to avoid the air duct being pressed.

Considering the air conditioners (compressor) should be kept standing upright, the increased height may hugely affect the loading of containers or trucks by decreasing one or more layers, which rise the transportation cost extremely. It also affects the terminal's express delivery freight and warehouse storage space and cost, etc.



- **General Portable Air Conditioner:**

In order to protect the exhaust hose, it is necessary to expand the packaging to reserve the space. Yet, the crush or the collapse still happens during the transportation.

- **Our Portable Air Conditioner:**

Packed in the unit, and fully protected the exhaust hose with durable plastic shell and foam.

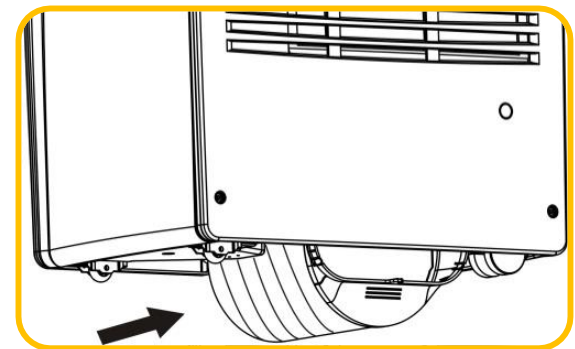

# Benefits

## □ Consumers Storage :

We store it directly in the unit, no additional packaging, no additional protection, what the user needs to do is to "fix the hose underneath the unit". On the contrary, other products in market need to be packed the unit and the hose separately. Moreover, the packaging material needs to be tested whether it is durable to protect the exhaust hose or whether it is dustproof. Last but not the least, the hose need to be kept by the unit to prevent the hose get lost.

While visitor comes, or while the weather changes rapidly, our products can be easily remove and hide, keeping the ambience clean and tidy. Other air conditioners in market, the exhaust hose can only be installed in the original position or be hung on the wall/ window which makes the room ugly and messy.



- **General Portable Air Conditioner :**  
Hang the exhaust hose on the wall/window, or hang it behind the unit, cumbersome and clumsiness.

- **Our Portable Air Conditioner:** ●----->  
Store in the unit after being folded, protected, dustproof, and not afraid of losing the exhaust hose.



# Features

Hot & Cold  
Convenient Air Outlet

Through the cold air outlet accessories (easily remove and assemble) and switching unit functions, you can enjoy different function modes and different applications.

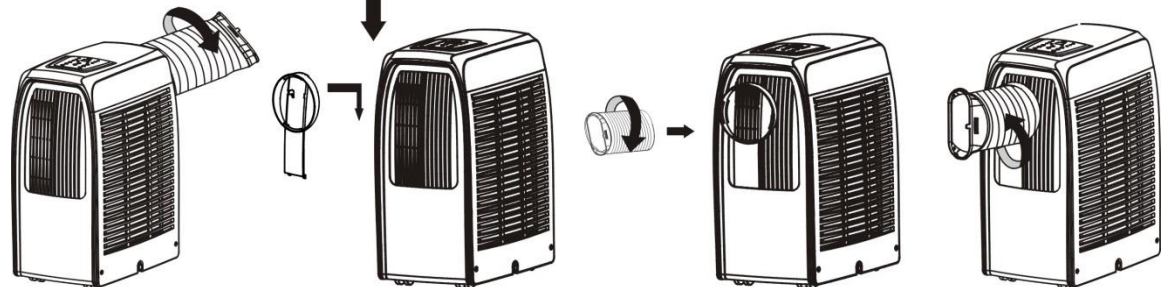
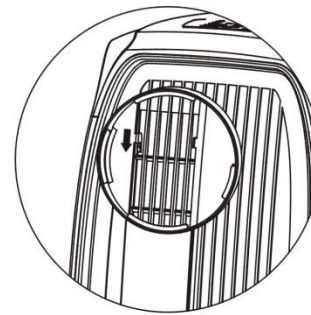

# Features

Indoor + Outdoor  
dust/raindrop resistant

The “cold/ hot air hose-adapter” and the “water resistant case and mechanism” enlarge the usage of portable AC.

**Unique Application!!** Place the unit outside(in yard or balcony with shelter) and deliver the desired air into the room.

**Solve!** The noise of compressor and motor

**Solve!** The limited indoor space.

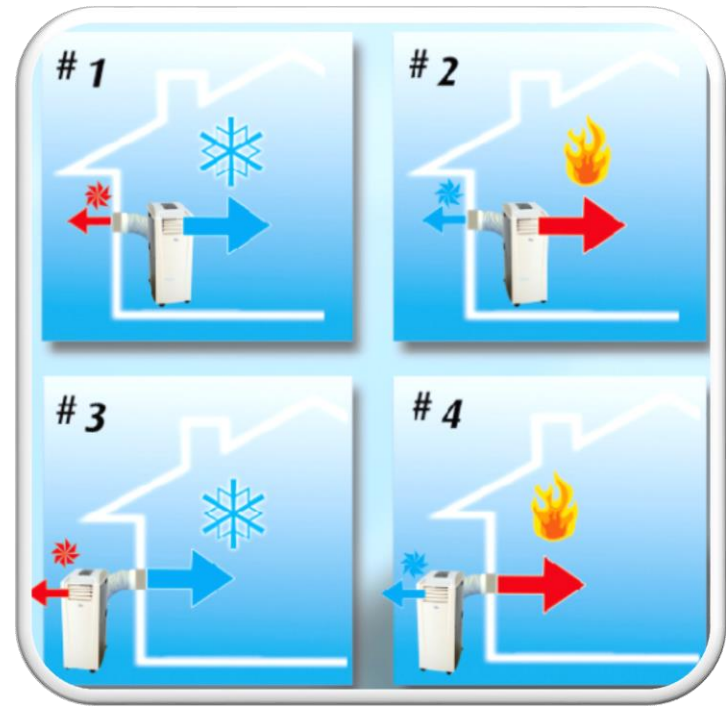

# Accessories

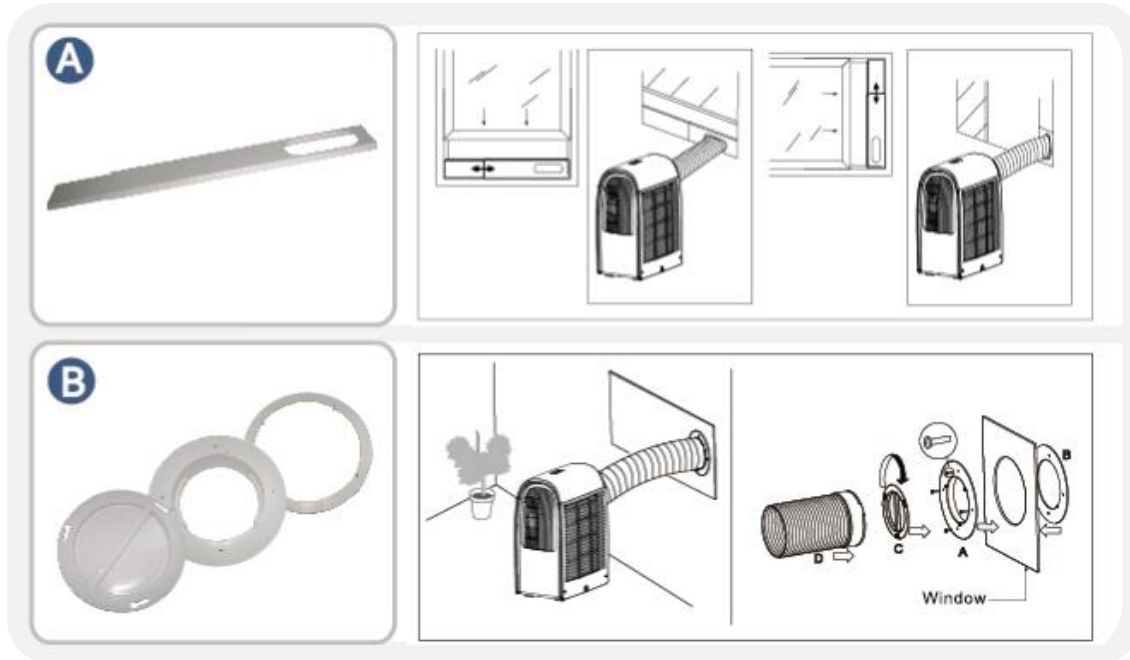

## Window Accessories

Enhance the airtightness of the space to ensure that the cold air is completely input or the heat is completely discharged to maximize the cooling effect of the room.

## Special Design:

*A) Type A (Straight Design)*  
Improve all the necessary accessories for portable air conditioners, build a window kit collections from more pieces, longer length, widen boards.

*B) Type B (Round Design)*  
Designed for windowless space with a sealing cover that covers the hole when not in use

- The straight window kit (type A) is the commonest accessory of portable ac. It is unnecessary to open the hole on the wall/window, you can fix the window kit on the window frame with screws without the tool easily.
- We have elaborate the straight type collection for the lengthen or widen windows in different countries.

**Straight window**

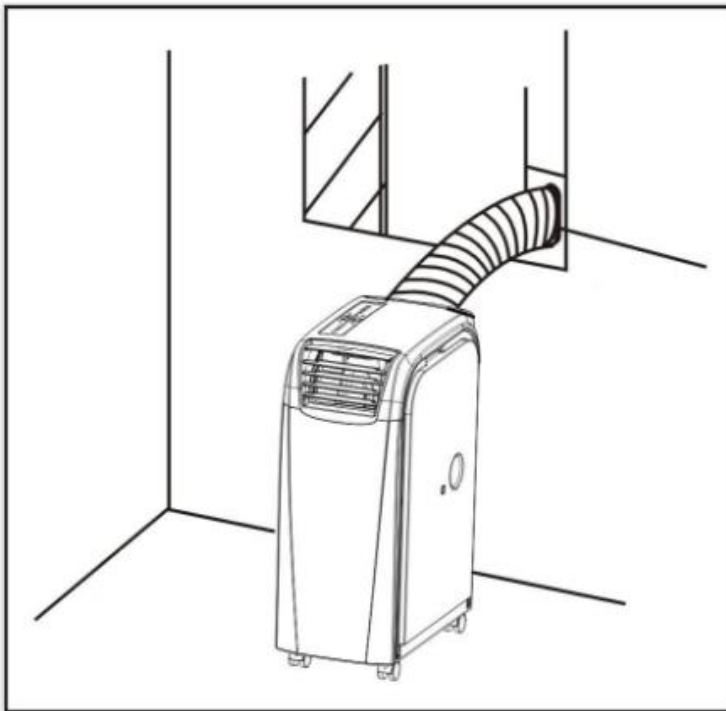

**Horizontal window**

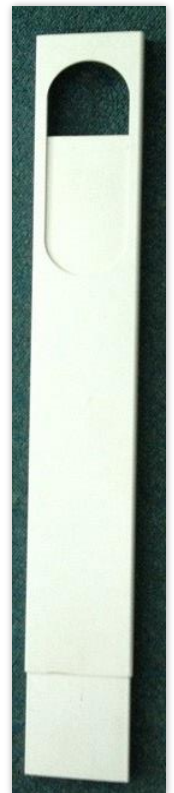
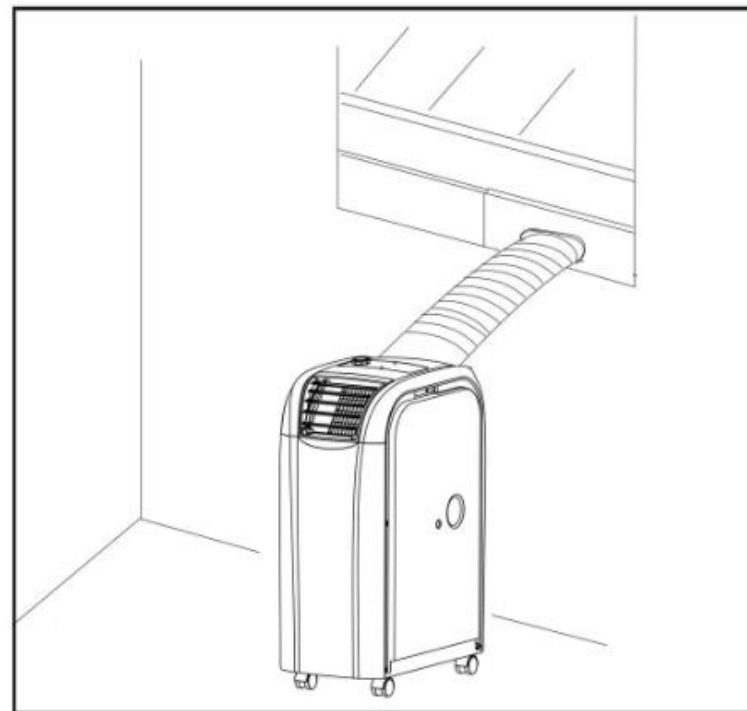



The Feature of the B-Type Window Kit is that when the unit is not stored, the hole can be covered with a cover to avoid the indoor and outdoor temperature being affected.

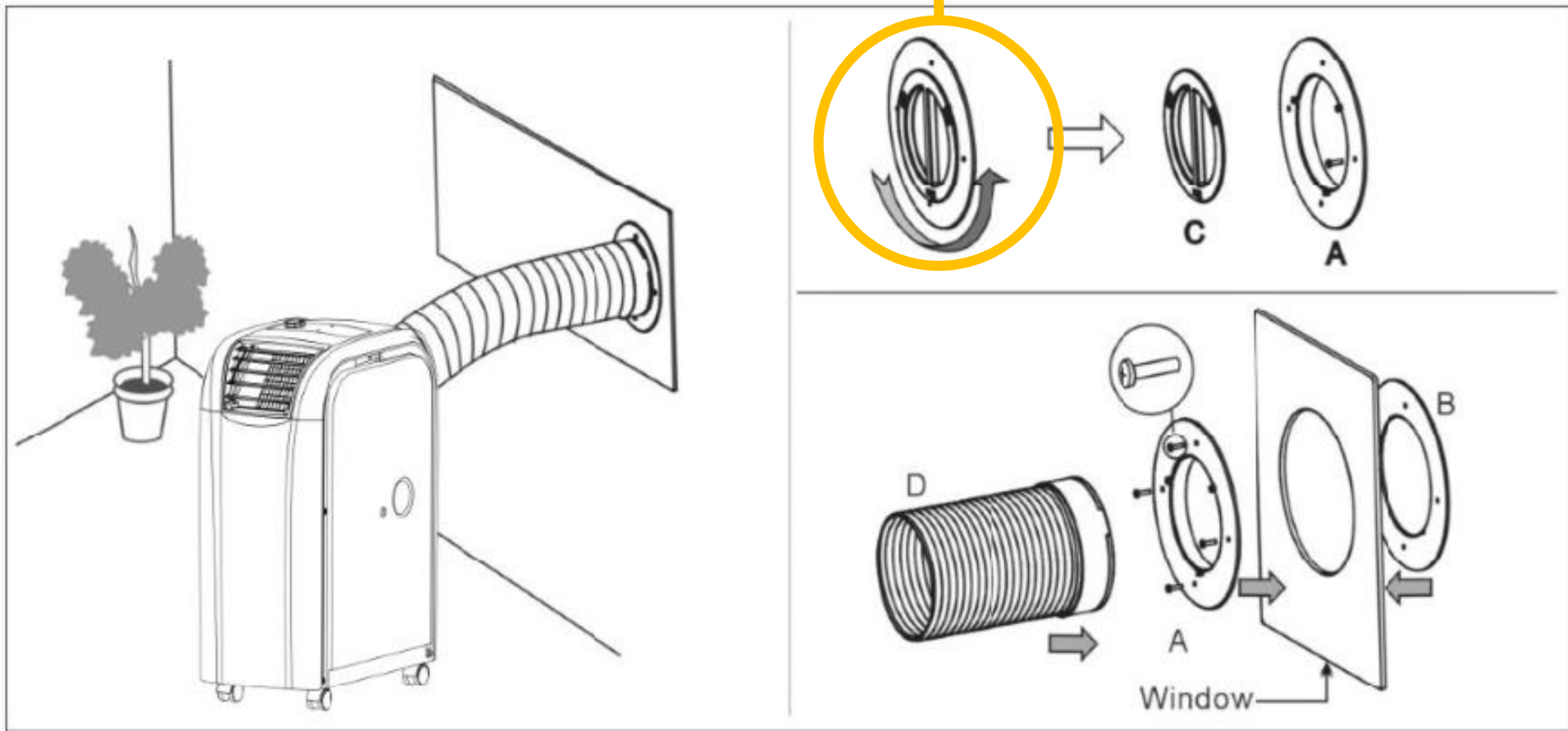



# Accessories

- **Smart Remote**
  - ✓ Wi-Fi control available
  - ✓ Simple UI
  - ✓ Fast pairing
  - ✓ Guest sharing





# Benefits



**Smart Remote**  
Wi-Fi Control

## Smartify Your Home:

Integrate and upgrade your appliances! Use smart remote to transform traditional appliances(control with infrared ray in room) to smart appliances(control with Wi-Fi signal anytime & anywhere).